

HM_SDTY
SUPER SLIM DUCT

> NEW



Whether installed in a ceiling void or in a suspended ceiling, the Super Slim Duct is easy to install and offers high performances as well as important energy savings.

Flexibility

- Whatever the capacity, the 210mm height and 450mm depth compact chassis is adapted to most projects
- Static pressure up to 50Pa set directly on the duct or by using a wired remote controller.

Comfort

- Noise level down to 26 dB(A) for quiet operation, especially well adapted for bedrooms
- 5-speed fan operation for perfect air flow adaptation.

Easy installation

- Built-in drain pump

SCOP MAX



4.35
A+

CAPACITY



2.5kW > 8kW

OPERATION



-27°C > +52°C

Prefilter included
Compatible with rear or underside
air suction.

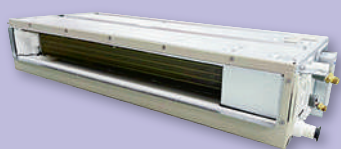
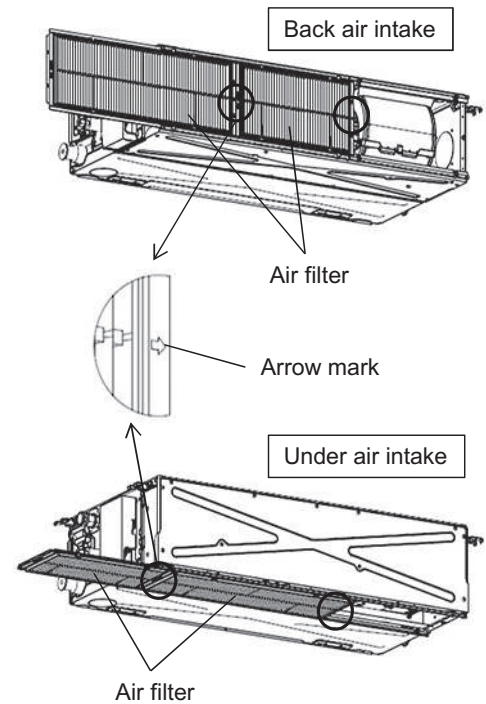

INDOOR UNITS

- RAV-HM301SDTY-E
- RAV-HM401SDTY-E
- RAV-HM561SDTY-E/TR
- RAV-HM801SDTY-E/TR

SDI



OUTDOOR UNITS

- RAV-GP561ATW-E/TR
- RAV-GP801ATW-E/TR

DI



- RAV-GM302ATP-E
- RAV-GM402ATP-E
- RAV-GM562ATP-E/TR
- RAV-GM802ATW-E/TR



REMOTE CONTROLS

- RBC-AXU31-E



- RBC-AMSU52-E
- RBC-AWSU52-E
- RBC-AMTU31-E
- RBC-ASCU11-E

SLIM DUCT - SERIES 1

SLIM DUCT Performance data with Super Digital Inverter Series 1 1Ph

Outdoor unit		RAV-GP561ATW-E/TR		RAV-GP801ATW-E/TR	
Indoor unit (Slim duct)		RAV-HM561SDTY-E/TR		RAV-HM801SDTY-E/TR	
Cooling capacity	kW	5.0		7.10	
Cooling range (min. - max.)	kW	1.2 - 5.6		1.9 - 8.0	
Power input (min. - rated - max.)	kW	C	0.19 - 1.54 - 1.98	0.26 - 1.85 - 3.44	
EER	W/W	3.24		3.83	
SEER		6.15		6.68	
Energy efficiency class		C	A++	A++	
Seasonal electricity consumption	kWh/a	C	284	372	
Heating capacity	kW	5.6		8.0	
Heating range (min. - max.)	kW	0.9 - 7.0		1.3 - 11.3	
Power input (min. - rated - max.)	kW	H	0.16 - 1.57 - 2.66	0.20 - 2.12 - 3.52	
COP	W/W	3.56		3.77	
SCOP		4.23		4.27	
Energy efficiency class		H	A+	A+	
Seasonal electricity consumption	kWh/a	H	1256	1669	

SLIM DUCT Performance data with Digital Inverter Series 2 1Ph

Outdoor unit		RAV-GM302ATP-E		RAV-GM402ATP-E		RAV-GM562ATP-E/TR		RAV-GM802ATW-E/TR	
Indoor unit (Slim duct)		RAV-HM301SDTY-E		RAV-HM401SDTY-E		RAV-HM561SDTY-E/TR		RAV-HM801SDTY-E/TR	
Cooling capacity	kW	2.5		3.6		5.0		6.7	
Cooling range (min. - max.)	kW	0.9 - 3.0		0.9 - 4.0		1.5 - 5.6		1.9 - 8.0	
Power input (min. - rated - max.)	kW	C	0.19 - 0.56 - 0.92	0.18 - 0.93 - 2.00		0.28 - 1.86 - 2.05		0.33 - 2.16 - 2.77	
EER	W/W	4.46		3.87		2.69		3.10	
SEER		6.41		6.03		5.80		5.63	
Energy efficiency class		C	A++	A+		A+		A+	
Seasonal electricity consumption	kWh/a	C	136	209		302		416	
Heating capacity	kW	3.4		4.0		5.3		7.7	
Heating range (min. - max.)	kW	0.8 - 4.5		0.8 - 5.0		1.5 - 6.3		1.6 - 9.0	
Power input (min. - rated - max.)	kW	H	0.17 - 0.86 - 1.40	0.17 - 0.97 - 1.70		0.22 - 1.50 - 2.40		0.31 - 2.24 - 2.66	
COP	W/W	3.95		4.12		3.53		3.44	
SCOP		4.35		4.00		4.00		4.00	
Energy efficiency class		H	A+	A+		A+		A+	
Seasonal electricity consumption	kWh/a	H	837	943		980		1783	

SLIM DUCT Physical data indoor

Indoor unit		RAV-HM301SDTY-E		RAV-HM401SDTY-E		RAV-HM561SDTY-E/TR		RAV-HM801SDTY-E/TR	
Air Flow (H/L)	m ³ /h - l/s	570/420		600/440		780/650		1140/910	
Sound pressure level (H-M-L)*	dB(A)	32-29-26		33-30-27		34-32-29		37-34-32	
Sound power level (H-M-L)	dB(A)	54-50-46		54-50-46		56-54-51		61-58-55	
Dimensions (HxWxD)	mm	210 x 700 x 450		210 x 700 x 450		210 x 900 x 450		210 x 1100 x 450	
Weight	kg	15		15		19		22	
External static pressure standard (Upper-Lower)	Pa	50-10		50-10		50-10		50-10	

C: cooling mode
H: heating mode
*bottom air inlet